

collateral

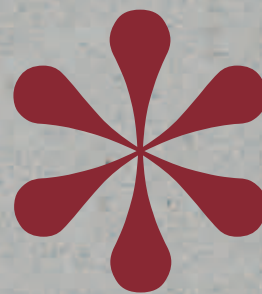

>> easy living and working <<

by  **Diemme**

> Per ampliare la propria offerta di sedute, Diemme ha pensato a questa nuova, stimolante e colorata collezione, frutto di una continua ricerca sul design e sulla creatività, che offre al cliente un'ampia scelta di sedute semplici e facili, dal design comunque ricercato e non banale, che si colloca a fianco della ormai consolidata produzione aziendale; da qui il nome "collateral".

Negli anni si è delineata una vasta gamma di prodotti per il contract, dimostrando la capacità del brand di inserirsi in grandi progetti in tutto il mondo, dagli alberghi ai negozi, dai musei agli aeroporti, senza dimenticare il settore casa.

Attraverso una gamma merceologica più articolata si punta ancora di più alla trasversalità, per prodotti idonei al settore contract, ma che possono trovare una collocazione in altri ambiti, come l'home, l'outdoor, il light office. Lungimirante e fedele a se stessa, Diemme è sempre pronta per affrontare nuove opportunità e sfide e nuovi mercati. Flessibilità ed un servizio sempre attento e puntuale sono le caratteristiche principali che l'azienda propone al cliente, come la capacità ed il coraggio di rinnovarsi sempre e sviluppare progetti ambiziosi. Un'azienda solida e che non ha paura di sperimentare. Diemme ha energia da vendere per il domani.

> Diemme has expanded its seating selection with this exciting, colourful new collection. It is the product of ceaseless research and creative efforts in a bid to offer customers a broad assortment of simple, straightforward seating with sophisticated designs to go alongside the well-established existing range, hence the name "collateral". Over the years, the company has built up a vast array of products for the contract market. They underline its capacity to contribute to big projects all over the world, everywhere from hotels and shops to museums and airports. Diemme is aiming to offer even greater versatility with its incre-

asingly extensive range. As well as being perfect for the contract market, its products are ideal for other settings such as homes, outdoor areas and light offices. Diemme is a far-sighted company that is always ready to seize fresh opportunities and take on new challenges and markets while remaining true to itself at all times.

Prompt, meticulous service and flexibility are the main characteristics that Diemme can offer its customers, along with the courage and capacity to develop ambitious projects and move with the times. It is a solid company that is not afraid to experiment. Diemme is bursting with energy for the future.

collateral collection

by  Diemme

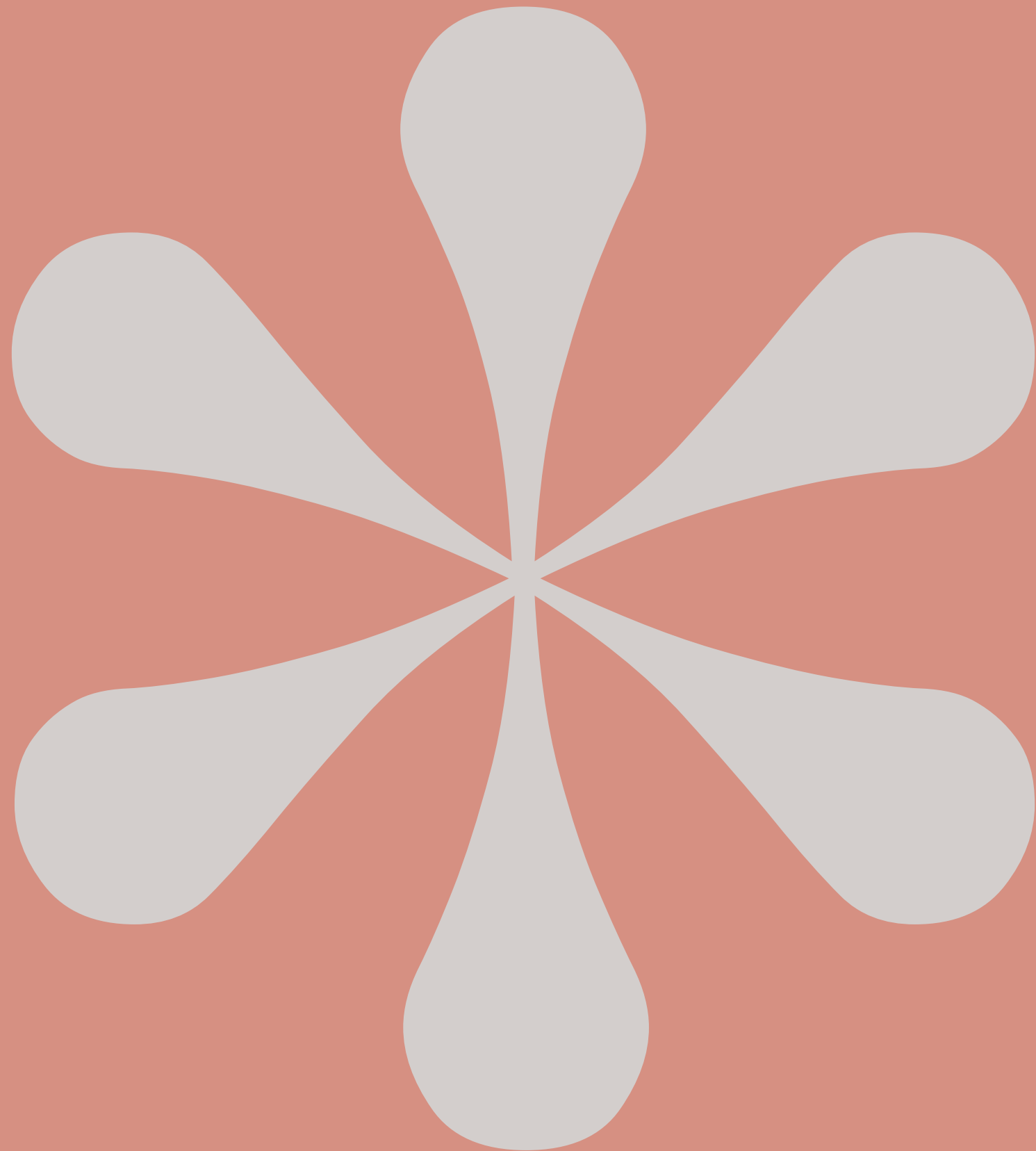

tavoli
tables



WELCOME
p. 30 - 31

complementi
complements



ROCKET
p. 60 - 61

sgabelli
tools



REDHOT
p. 20 - 21

OBLO
p. 32 - 33

sedie
chairs



CLEA/ CLEA PLUS
p. 2 - 11



REDHOT
p. 12 - 17



NO FRILL
p. 22 - 29



NUKE
p. 34 - 45



KONTÈ
p. 46 - 53



PERFECTA
p. 52 - 57



AIDA
p. 58 - 59

indice <
index

Clea Plus >>



> Giovinezza, versatilità e comfort sono le parole chiave della personalità di Clea Plus, una sedia proposta con diverse basi pronta ad entrare in sintonia con qualsiasi ambiente e a proporre abbinamenti inattesi nei materiali e nei colori, sia per l'ufficio che per il contract.

> The character of Clea Plus can be summed up in three words: youthful, versatile and comfortable. With its selection of bases, the chair is the perfect match for any setting. All sorts of breathtaking combinations of materials and colours are possible, to cater to the needs of both offices and the contract market.





Clea Plus >>



> Clea Plus è un modello dal design semplice ed elegante, creato per sale d'attesa, comunità e contract. La seduta spaziosa è imbottita con poliuretano espanso, per garantire il massimo comfort. Per il rivestimento è possibile scegliere in una vasta gamma di tessuti, pelli e colori.

> Clea Plus has a simple, stylish design that was conceived for waiting rooms, public spaces and the contract market. The spacious, cosy seat is padded with polyurethane foam for maximum comfort. A vast range of fabrics and colours are available for the upholstery.



<< Clea



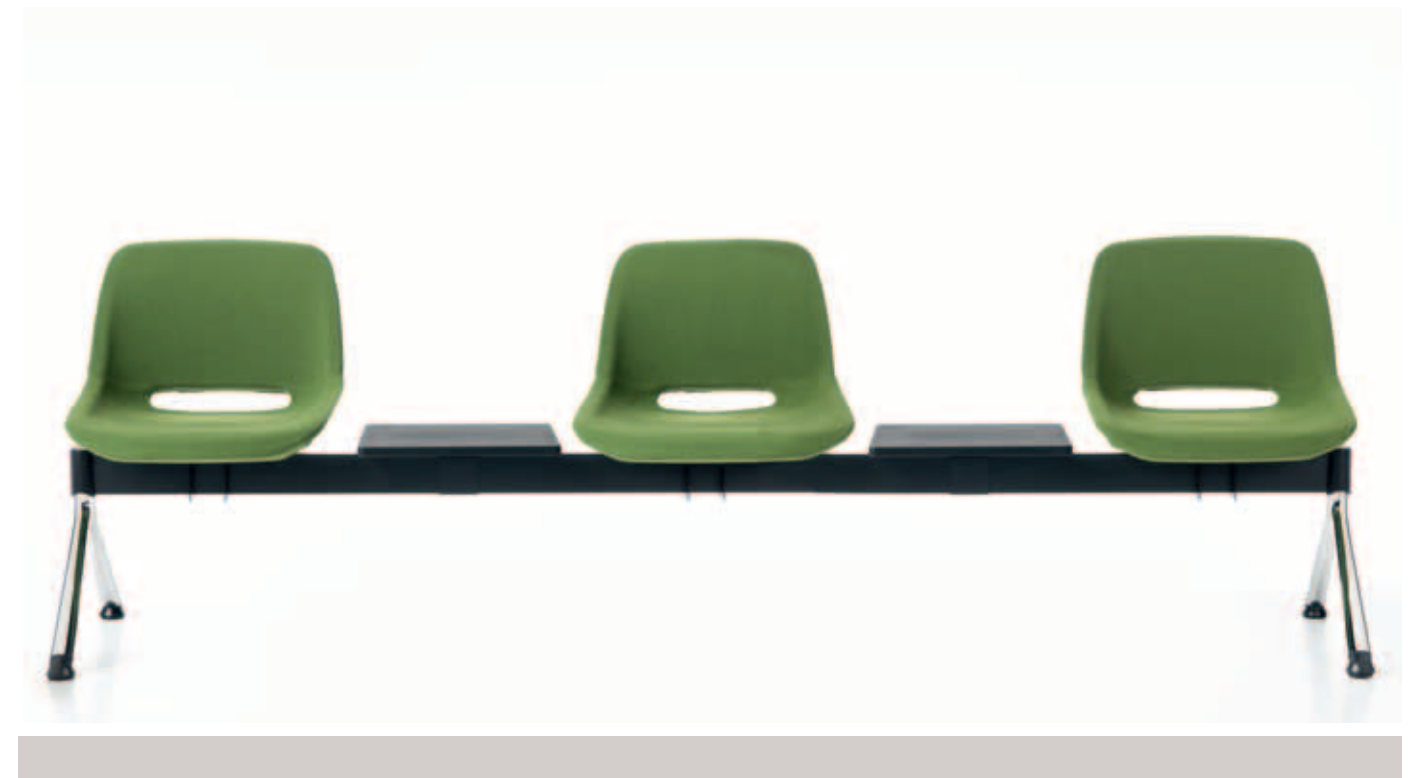

Clea >>

> Clea, più che una sedia è una piccola poltroncina creata per aree collettive; si caratterizza per i contenuti di design e funzionalità, determinata questa da elevati livelli prestazionali e dal confort della seduta, assicurato anche in situazioni prolungate.

> Clea is actually a small armchair that has been created for public spaces. It combines a stylish design with practical aspects such as exceptional performance and guaranteed comfort from the seat even during extended use.



> Decisa nelle linee e giovane nell'ispirazione, leggera e maneggevole, Red Hot è una seduta assolutamente versatile e funzionale. Il design non è studiato solo per dare carattere e personalità agli spazi abitativi ma per offrire anche il confort e il benessere di una seduta ergonomica.

>With its bold lines and youthful feel, the light, easy-to-handle Red Hot is a highly versatile and practical seat. It is designed not only to add character and personality to homes but also to offer the comfort and wellbeing provided by ergonomic seating.

<< RedHot



> Diverse le basi abbinabili alla seduta che può essere semplice o imbottita, in tinta o in contrasto con il basamento, sempre comunque estremamente confortevole.
> A range of bases can be combined with the seat, which can be simple or padded: either way it is extremely comfortable.



RedHot >>





> Curve studiate per sagomare le superfici e per valorizzare confort e ergonomia, con le quali creare ambienti unici, informali, creativi. Lo sgabello completa con carattere e forte identità la collezione Redhot.

> The curves are designed to shape the surfaces and offer enhanced comfort and ergonomics, which foster unique, casual and creative atmospheres. The strong identity and personality of the stool complement the Redhot collection.

<< RedHot / Welcome



RedHot >>

> Il filo conduttore è la leggerezza; tutta la serie Redhot si contraddistingue per linee eleganti e spessori sottili esaltati da un design puro ed essenziale. Due i basamenti disponibili per una seduta che garantisce ergonomia e comfort anche in uno sgabello.

> Lightness is the common thread running throughout the Redhot range, whose pure, simple design brings out the best of the graceful lines and slender forms. A choice of two bases is available for the seat, which also guarantees ergonomics and comfort in the form of a stool.





>Una linea giovane, resa particolarmente fresca anche dagli esili spessori della scocca della seduta proposta in diversi vivaci colori e studiata per diverse esigenze e funzioni. La serie è composta da diversi basamenti e dalla scocca di seduta intera estremamente confortevole.

>This youthful line is given a particularly fresh touch by the slender body of the seat, which comes in a number of bright colours and is designed for a range of needs and purposes. The selection features a variety of bases and an extremely comfortable full seat.

<< NoFrill

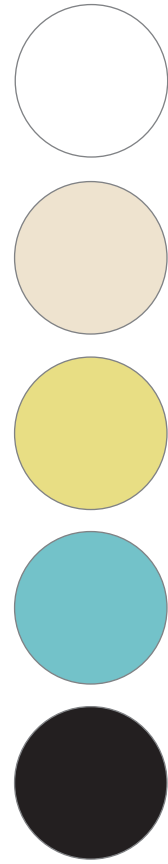

<< NoFrill

> Versione sobria, lineare e molto elegante quella composta da telaio verniciato nero o bianco con seduta monoscocca ampia e confortevole.
> The restrained, linear and extremely elegant item features black or white coating on the frame and a single-piece seat in one colours.





> Pensata per chi ama il design contemporaneo, NoFrill è una sedia dalla linea fresca e attuale, che privilegia il confort e la robustezza per garantire la massima praticità. Ideale per ogni ambiente, è disponibile anche con braccioli e corredata da pratici accessori, come la tavoletta scrittoio.

> Conceived for lovers of contemporary design, NoFrill is a chair with fresh, cutting-edge lines that places the emphasis on comfort and sturdiness, guaranteeing maximum practicality. Ideal for all settings, it is also available with armrests and practical accessories, such as the writing tablets.

<< NoFrill



NoFrill >>

> In equilibrio tra funzionalità e design, NoFrill diventa la sintesi di un'estetica capace di trasformare l'ambiente in uno spazio personalizzato, di una modernità fatta di linee semplici e pulite. Un design che non è frutto di una tendenza, ma di un oggetto senza tempo.

> With its finely poised balance between practicality and aesthetic appeal, No Frill can add a personal touch to any setting. Its simple, clean-cut lines have a highly contemporary feel. Passing trends play no part in the astonishing, understated simplicity of this design.





No Frill / Welcome >>

> Una linea continua di stile tra la sedia NoFrill e il tavolo Welcome. Un connubio perfetto tra linee curve e leggeri spessori che si intersecano in un armonioso equilibrio. Welcome è disponibile in due diverse altezze, sempre con basamento cromato e piano rotondo.

> The No Frill chair and Welcome table are on the same style and design spectrum. Curved lines and slender forms make a perfect pairing as they are interwoven in magnificent balance. Welcome comes in two different heights, both with a chrome base and a round top.





Oblò >>



> Caratterizzato da una seduta imbottita estremamente ergonomica, Oblò è uno sgabello dal design giovane, spiritoso, innovativo e dal grande confort. Una seduta comoda e sicura, e con un aiuto in più: la base oscillante segue i movimenti del corpo garantendo massima presa a terra.

> Oblò is a stool with a vivacious, innovative and extremely comfortable design, featuring a highly ergonomic padded seat. A comfortable, steady seat that offers a helping hand: the rocking base follows the movements of the body and guarantees maximum adherence to the ground.





> Una linea raffinata e modernissima, un tratto di puro design: Nuke è una sedia dalle forme avvolgenti estremamente confortevole, protagonista degli spazi collettivi ma anche di quelli domestici con stile ed allegria.

> A refined, cutting-edge line displaying unadulterated design: Nuke is a chair with exceptionally comfortable, enveloping forms that can stylishly, cheerfully take centre stage in both public and residential spaces.

<< Nuke

Nuke >>



> Forte nella struttura e leggera nella linea, Nuke è una sedia in polipropilene dalle dimensioni contenute proposta in diversi e accattivanti colori, disponibile con e senza braccioli. Impilabile ed ergonomica, con la sua forma pulita e razionale è perfetta per aule ed uffici.

> Nuke is a compact polypropylene chair with a strong structure and light lines. It is available in a selection of attractive colours, both with and without armrests. Stackable and ergonomic, its clean-cut, rational shape makes it perfect for classrooms and offices.

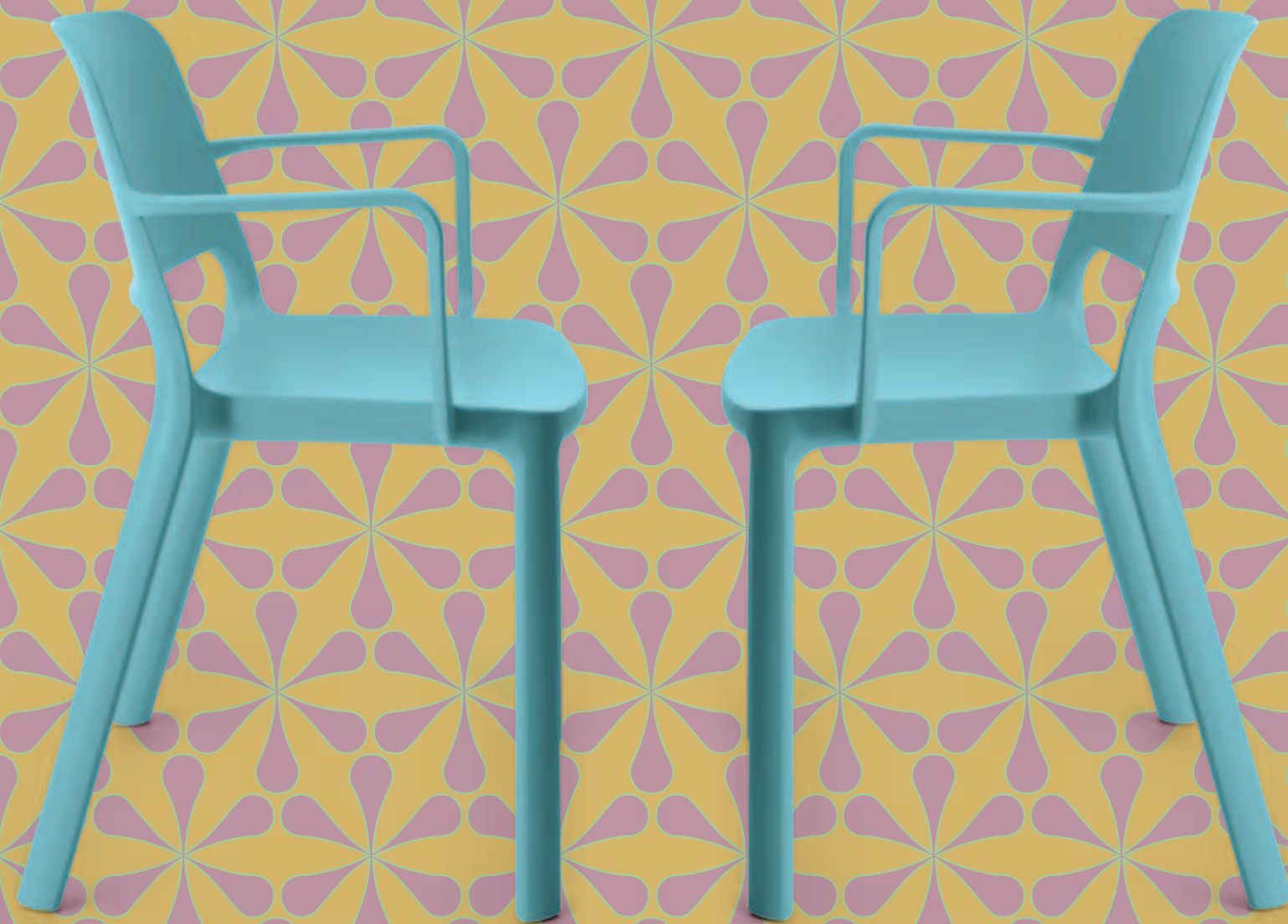



<< Nuke

> Dalle linee morbide e stondate, ma progettata nel segno della razionalità, Nuke è perfetta per gli ambienti collettivi dove stile e praticità devono andare d'accordo. Dalla seduta spaziosa e confortevole, nella versione con bracciolo assume il ruolo di una comoda poltroncina.

> With its blend of rational design and soft, rounded lines, Nuke is a perfect chair for public places where a balance is required between style and practicality. The seat is spacious and comfortable. The version with armrests makes a wonderfully cosy armchair.





> Assolutamente versatile, Nuke è una sedia polifunzionale dal design fresco e contemporaneo; pratica, maneggevole e rapidamente impilabile, occupa il minimo spazio e garantisce allo stesso tempo comodità e ordine. E' disponibile in quattro diversi, accattivanti colori.

> The magnificently versatile Nuke is a multipurpose chair with a fresh, contemporary design. Practical, easy-to-handle and quick to stack, it takes up as little space as possible and combines comfort and tidiness. It comes in four different, attractive colours.

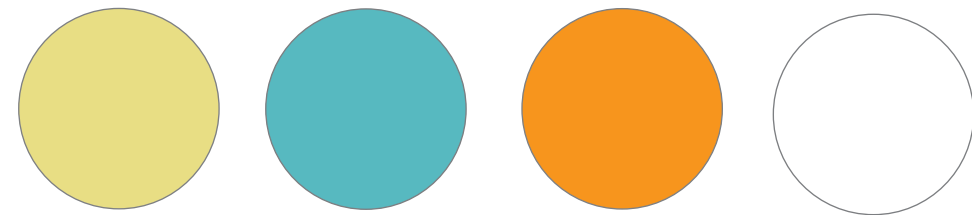

<< Nuke

Nuke >>



> Un design che privilegia freschezza ed allegria senza dimenticare il confort; che si ispira alla purezza e lo arricchisce di nuovi ritmi.
> A design that harnesses cheerful freshness without neglecting comfort: it draws inspiration from purity and imbues it with a new tempo.



> Kontè non è stata concepita come seduta statica, ma come un sistema di sedute ampliabile e personalizzabile a seconda della scelta del basamento e del rivestimento. Metallo e legno sono i due elementi materici che si uniscono alla parte imbottita per creare diverse soluzioni al fine di conferire al modello un design particolare, unico, riconoscibile.

> Rather than a fixed solution, Kontè was conceived as a seating selection that can be extended and customized with different base and upholstery choices. Metal and wood are combined with a padded section to create a variety of options and give the product a distinctive, unique and recognizable style.

<< Kontè



Kontè >>

>Una linea continua che unisce il classico e il moderno. Kontè ripercorre la storia della sedia reinterpretandola nel gusto dei nostri giorni. Rappresenta la massima maestria delle lavorazioni e dei dettagli applicata al rivestimento, sia in tessuto che in pelle.

>An unbroken line between the classic and the modern. Kontè retraces the history of the chair and gives it a fresh twist to suit contemporary tastes. It is the epitome of unparalleled workmanship and bringing out the best of details in both fabric and leather upholstery.





Kontè>>

> Kontè non è solo una sedia, ma un progetto che interpreta una seduta come un sistema disegnato per sedersi in ogni posto della nostra vita quotidiana garantendo il massimo del confort. Una collezione disponibile con diversi basamenti, in metallo o legno.

> Kontè is more than just a chair: it is a project that sees a seat as a system designed to let us sit down in any location in our daily lives, guaranteeing maximum comfort. The stylish collection comes with a variety of metal and wooden bases.





Kontè >>

> L'eleganza s'identifica nei dettagli e nel confort grazie alle particolari imbottiture, progettate per offrire un'avvolgente ergonomia.

> The detailing and comfort add a very stylish touch. The distinctive padding has been designed to offer enveloping ergonomics.





Perfecta >>



> Decisa nelle linee e giovane nell'ispirazione, Perfecta è la sedia ideale per spazi collettivi contemporanei, sale d'attesa, uffici dove diventa importante proporre sedute comode e funzionali con le quali creare ambienti sobria accoglienti e creativi.

> With its bold lines and youthful feel, Perfecta is the perfect chair for contemporary public spaces, waiting rooms and offices where it is essential to provide comfortable, practical seating that can help to produce a restrained but welcoming and creative atmosphere.

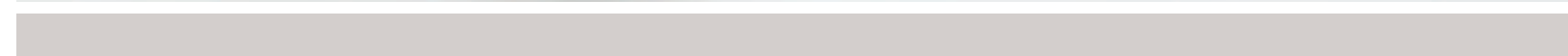

> La serie Perfecta è un programma di sedute polifunzionali da un design giovane che valorizza confort ed ergonomia. Sono disponibili il bracciolo dotato di tavoletta scrittoio e un aggancio da basamento per permettere le composizioni in file.

> The multi-purpose Perfecta seating selection has a vibrant, attractive design that makes comfort and ergonomics a top priority. An armrest with a writing tablet is available, as is a clip to attach to the base for setting out the seats in rows.



<< Perfecta



> Perfecta si ispira ai canoni formali tradizionali introducendo elementi di contemporaneità nel disegno, nel materiale e nella tecnologia costruttiva.

> Perfecta takes inspiration from traditional shaping principles while giving a contemporary twist to its design, material and construction technology.

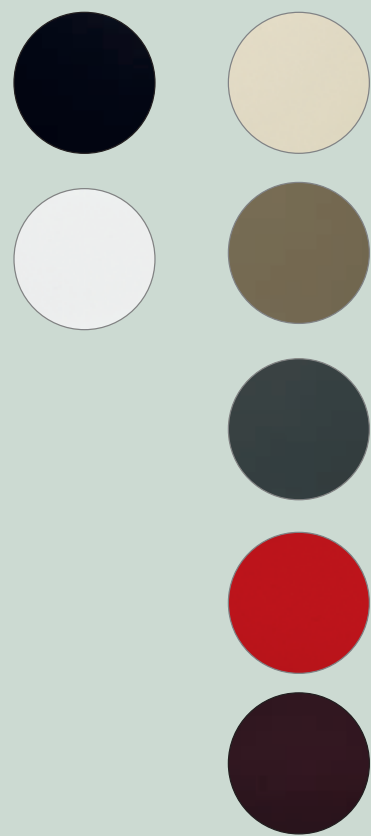

Aida >>

> Snella, robusta e molto versatile, Aida è un modello dal design sobrio e lineare realizzato con un telaio di metallo completamente rivestito in cuoio.

> Streamlined, sturdy and extremely versatile, Aida is a product with an understated, linear design and a metal frame that is completely covered with leather.





> Le stanze si vestono di nuovi elementi e di nuovi colori. Appendiabiti e portaombrelli diventano un oggetto di design allegro e piacevole, quasi un gioco da appendere anche a parete. Originali e spiritosi, disponibili in vari colori, vestono di allegria lo spazio in cui vengono collocati.

> Rooms are adorned with new features and colours. Coat and umbrella stands and hooks with pleasant, cheerful designs are almost like toys, which can be wall-mounted. Fun and original, they come in a number of colours and really brighten up their surroundings.

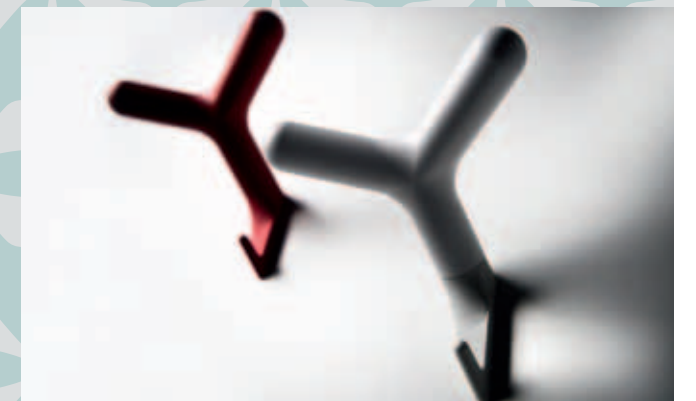

Rocket >>



> Produciamo sedute da più di un ventennio. Nata nella tradizione del migliore design, la nostra è un'azienda sinonimo di qualità. La regola è lavorare principalmente sui materiali, l'obiettivo è creare prodotti rigorosamente made in Italy. La squadra ha come punto di forza quello di sperimentare continuamente le novità. Ciò che ci contraddistingue sul piano produttivo è un forte binomio tra tradizione e tecnologia. I nostri prodotti sono rifiniti in maniera artigianale ma sfruttiamo ogni nuova opportunità dell'industria per raggiungere la più alta qualità. Altro punto di forza è la lunga storia artigianale dell'azienda. Una storia che rivive ogni giorno grazie ad una catena di montaggio fatta di operatori che agiscono in perfetta sincronia con le macchine di lavorazione. Le macchine garantiscono l'alta precisione, mentre gli artigiani lavorano con sensibilità e competenza la rifinitura dei dettagli, trattando i prodotti come veri e propri prodotti di alta sartoria.

> We have been making seating products for more than 20 years. Our company is the epitome of quality and it is steeped in the finest design traditions. Our golden rule is to work mainly on materials and our goal is to create products that are 100% made in Italy. Constantly experimenting with innovative approaches is one of the strengths of our team. Our distinguishing feature on the production front is a proficient pairing of tradition and technology. While we use craft techniques to finish our products, we also make the most of all forms of industrial innovation to achieve the very best quality. Another one of our company's strengths is its vast craft experience. Its illustrious history is brought to life every day thanks to the perfect synchronism between the processing machines and the staff on the assembly line. The machines guarantee great precision, while the craft workers show exceptional sensitivity and expertise in the finishing details, treating the products like the finest sartorial creations.

Qualità e competenza / Quality and expertise >>

Aida

Sedia a 4 gambe lineare ed eclettica. Struttura interna in metallo, rivestita di cuoio rigenerato. Disponibile in 7 varianti di colore: grigio, tortora, nero, bianco, beige e testa di moro.

Linear and eclectic chair on 4 legs. Metal inner structure, coated in regenerated leather. Available in 7 different colors: grey, dove, black, white, red, beige and dark brown.

Chaise linéaire et éclectique sur 4 pieds. Structure intérieure en métal, revêtue de cuir régénéré. Disponible en 7 couleurs différentes: gris, gris tourterelle, noir, blanc, rouge, beige et marron foncé.

Silla lineal y ecléctica de 4 patas. Estructura metálica con revestimiento de cuero regenerado. Disponible en 7 colores diferentes: gris, tórtola, negro, blanco, rojo, beige y marrón oscuro.

Aida

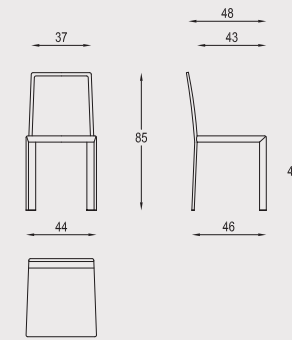

Welcome

Tavolo rotondo con piano in HPL bianco ø 70 cm e struttura in metallo cromato con base a calice. Disponibile in due altezze: h 70 cm e h 110 cm.

Round table with HPL white top ø 70 cm and chromed metal structure with trumpet base. Available in two different heights: h 70 cm and h 110 cm.

Table rond avec top en HPL blanc ø 70 cm et structure en métal chromé en forme de trompette. Disponible en deux hauteurs: h 70 cm et h 110 cm.

Mesa redonda con tope blanco en HPL ø 70 cm y estructura metálica cromada con base a copa. Disponible en dos alturas diferentes: h 70 cm y h 110 cm.

Welcome alto

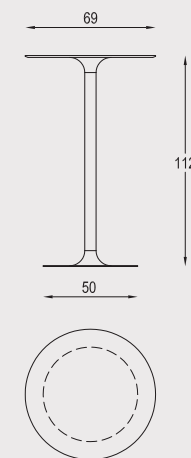

Welcome basso

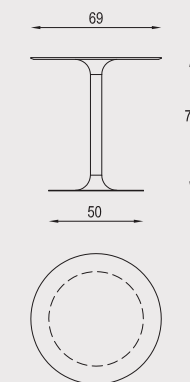

Clea

Seduta dalla linea sinuosa, con struttura interna in acciaio e imbottitura in poliuretano schiumato a freddo. Disponibile su vari basamenti: base girevole 5 razze in alluminio con alzata gas su ruote gommata, base 4 lame in alluminio con meccanismo di ritorno automatico, base girevole a 4 razze in tubolare di acciaio, base slitta cromata o base piramidale in alluminio verniciata bianca o antracite. Con o senza braccioli tubolari cromati. Disponibile anche la versione panca a 2, 3, 4 o 5 posti, perfetta per sale d'attesa.

Armchair characterized of sinuous line, with steel interior and cold-foamed polyurethane padding. Available with different types of legs/bases: swivel base in chromed steel, 5-stars aluminium base on self-braking rubber castors with gaslift, 4-blades aluminium base with self-return mechanism, sled chromed base or aluminium pyramidal base painted white or dark grey. With or without chromed tubular armrests. Also available on bench version for 2, 3, 4 or 5 seaters, perfect for waiting areas.

Petit fauteuil caractérisé par une ligne sinueuse, avec structure en acier et rembourrage en mousse de polyuréthane à froid. Disponible avec différents types des piétements: 4 rayons tubulaires pivotante en acier chromé, 5-rayons sur roulettes avec réglage hauteur gaz, 4-rayons en aluminium avec mécanisme de retour automatique, luge chromé et pyramidale en aluminium peinté blanc ou gris foncé. Avec ou sans accoudoirs tubulaires chromés. Aussi disponible en version banquette 2, 3, 4 ou 5 places, parfaite pour salles d'attente.

Butaca caracterizada por una línea sinuosa, con estructura de acero y acolchado de poliuretano espumado en frío. Disponibles con diferentes tipos de estructuras: giratoria de acero cromado, 5 radios de aluminio pulido con ruedas engomadas y elevador de gas, base de aluminio 4 radios con mecanismo de auto-retorno, base trineo cromada o piramidal giratoria de aluminio pintado de blanco o antracita. Con o sin apoyabrazos tubulares cromados. Disponible también en la versión banco de 2, 3, 4 o 5 asientos, perfecto para salas de espera.

Clea piram

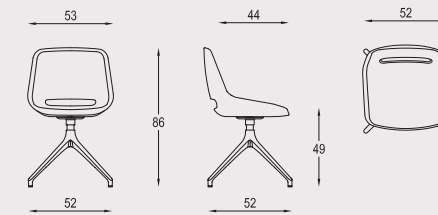

Clea slitta

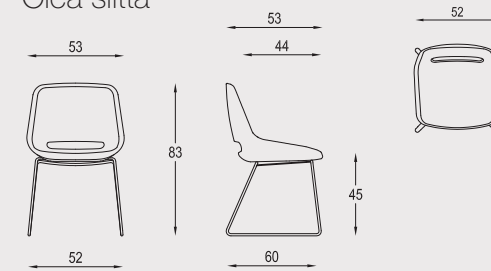

Clea 4piram + braccioli

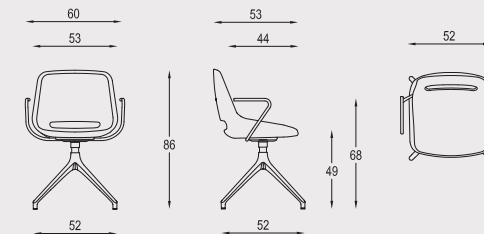

Clea slitta + braccioli

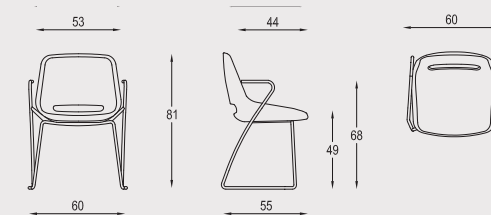

Clea 4 lame

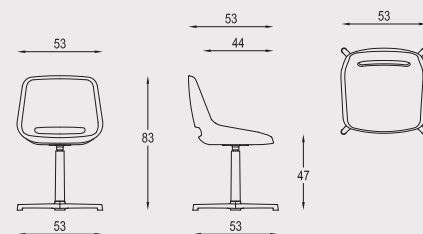

Clea 4 razze

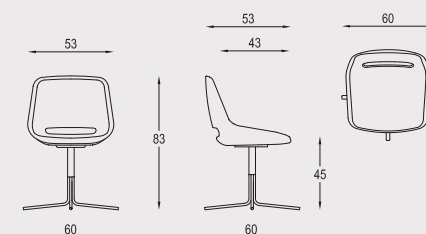

Clea gas

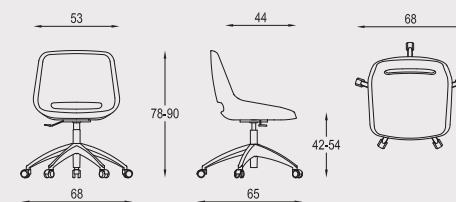

Clea 4 lame + braccioli

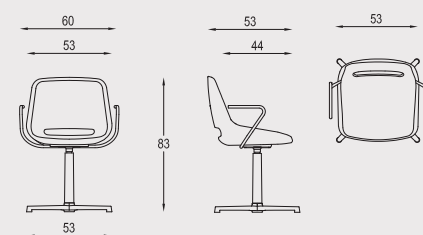

Clea 4 razze + braccioli

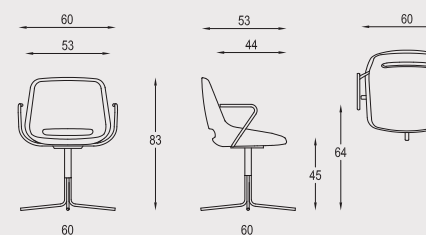

Clea gas + braccioli

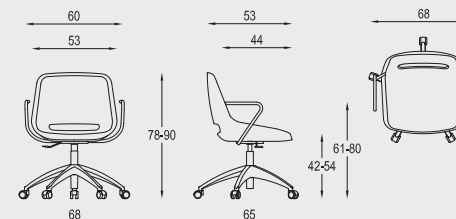

Clea panca 2P

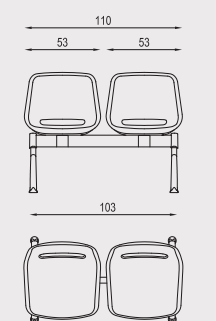

Clea panca 3P

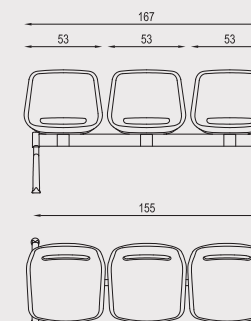

Clea panca 4P

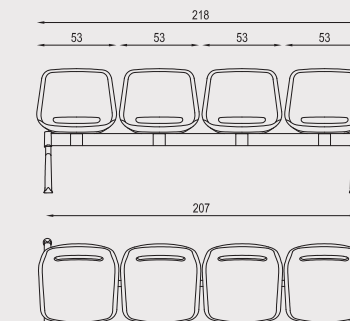

Clea panca 5P

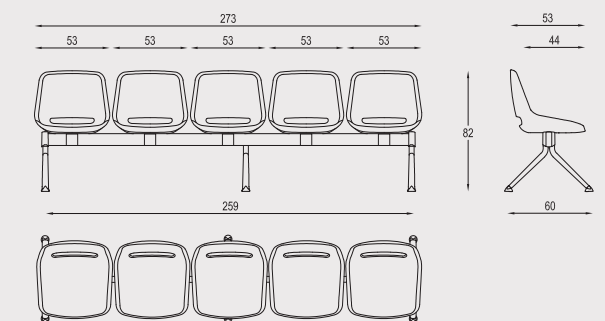

Clea Plus

Poltroncina dalla linea sinuosa, con struttura interna in acciaio e imbottitura in poliuretano schiumato a freddo. Disponibile su vari basamenti: base girevole 5 razze in acciaio con alzata gas su ruote gommate, base 4 lame in alluminio con meccanismo di ritorno automatico, base girevole a 4 razze in tubolare di alluminio, base slitta cromata o base piramidale in alluminio verniciata bianca o antracite.

Armchair characterized of sinuous line, with steel interior and cold-foamed polyurethane padding. Available with different types of legs/bases: swivel base in chromed steel, 5-stars aluminium base on self-braking rubber castors with gaslift, 4-blades aluminium base with self-return mechanism, sled chromed base or aluminium pyramidal base painted white or dark grey.

Petit fauteuil caractérisé par une ligne sinueuse, avec structure en acier et rembourrage en mousse de polyuréthane à froid. Disponible avec différents types des piétements: 4 rayons tubulaires pivotante en acier chromé, 5-rayons aluminium sur roulettes avec réglage hauteur gaz, 4-rayons en aluminium avec mécanisme de retour automatique, luge chromé et pyramidale en aluminium peint blanc ou gris foncé.

Butaca caracterizada por una línea sinuosa, con interior de acero y acolchado de poliuretano espumado en frío. Disponibles con diferentes tipos de estructuras: giratoria de acero cromado, 5 radios de aluminio pulido con ruedas engomadas y elevador de gas, base de aluminio 4 radios con mecanismo de auto-retorno, base trineo cromada o piramidal giratoria de aluminio pintado de blanco o antracita.

Clea Plus piram

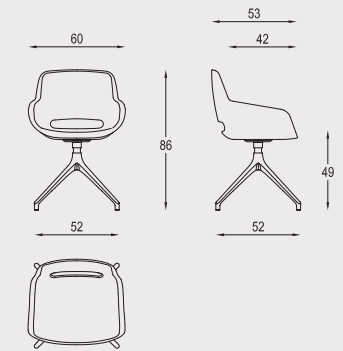

Clea Plus slitta

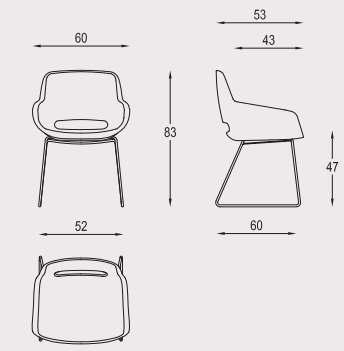

Clea Plus

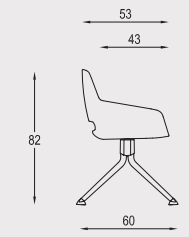

Clea Plus panca 2P

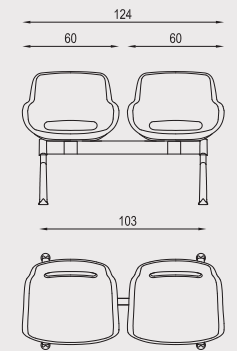

Clea Plus 4 lame

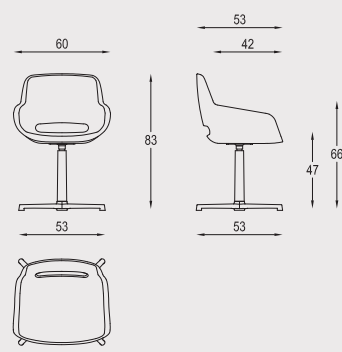

Clea Plus 4 razze

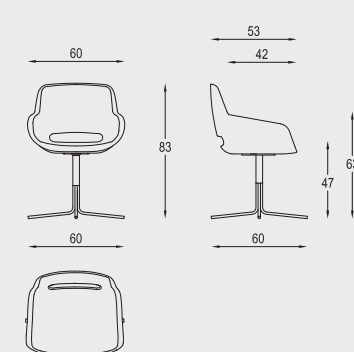

Clea Plus gas

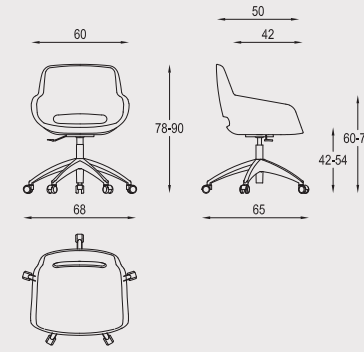

Clea Plus panca 3P

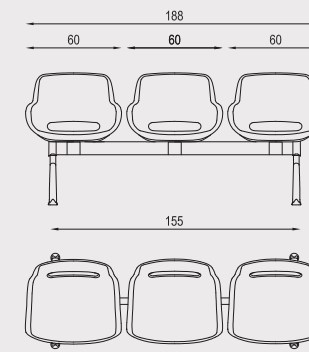

Clea Plus panca 4P

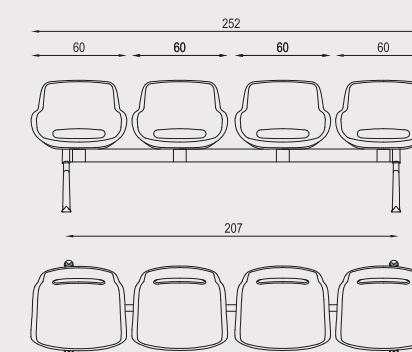

Clea Plus panca 5P

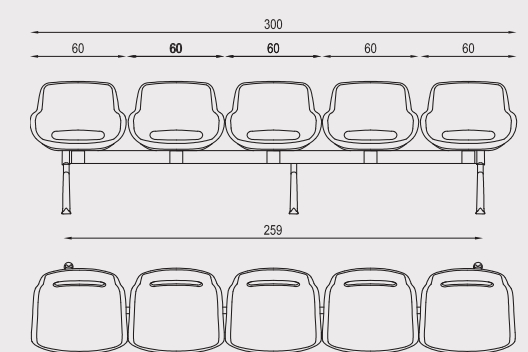

Kontè

Poltroncina dalla linea elegante, struttura interna in acciaio e imbottita in poliuretano schiumato a freddo e completamente rivestita. Disponibile su vari basamenti: base girevole a 5 razze in alluminio con alzata gas su ruote gommate, base a 4 lame in alluminio con meccanismo di ritorno automatico, base girevole a 4 razze in tubolare di acciaio cromato, base piramidale di alluminio verniciata bianca o antracite o a 4 gambe in legno verniciato naturale o nero.

Elegant armchair with internal structure in steel, padded in cold-foamed polyurethane and completely upholstered. Available with different types of legs/bases: swivel base in chromed steel, 5-stars aluminum base on self-braking rubber castors with gaslift, 4-blades aluminium base with self-return mechanism, aluminium pyramidal base painted white or dark grey or 4 wood legs painted in natural shade or black.

Petit fauteuil élégant avec structure interne en acier, rembourré en mousse de polyuréthane à froid et complètement rembourré. Disponible avec différents piétements: 4 rayons tubulaires pivotante en acier chromé t, 5-rayons sur roulettes avec réglage hauteur gaz, 4-rayons en aluminium avec mécanisme de retour automatique, pyramidale en aluminium peint blanc ou gris foncé et 4 pieds en bois peint en teinte naturelle ou noirs.

Elegante butaca con estructura de acero acolchada de poliuretano espumado en frío. Disponibles con diferentes tipos de estructuras: giratoria de acero cromado, 5 radios de aluminio pulido con ruedas engomadas y elevador de gas, base de aluminio 4 radios con mecanismo de auto-retorno, piramidal giratoria de aluminio pintado blanco o antracita o 4 patas con acabado de madera barnizada en tono natural o negro.

Konté 4 razze

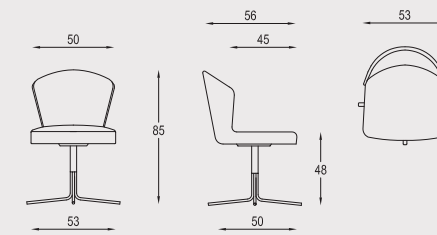

Konté 4 lame

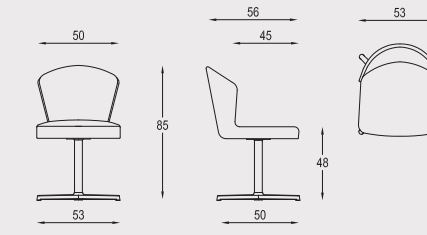

Konté 4G legno

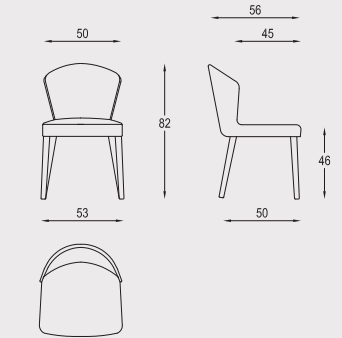

Konté gas

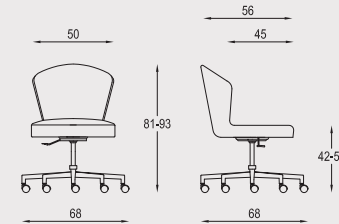

Konté piram

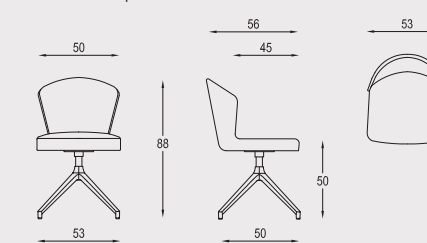

No Frill

Sedia dalla linea essenziale ed accattivante. Telaio in metallo verniciato bianco, nero oppure cromato, disponibile nella versione base slitta o a 4 gambe con o senza braccioli fissi. Monoscocca in polipropilene disponibile in 6 varianti di colore: azzurro, giallo, beige, bianco e antracite. Possibilità di avere il sedile imbottito e rivestito. Impilabile fino a 6 pezzi.

Chair with an essential, eye-catching line. Metal frame chromed or painted white or black, available with 4 legs base with or without fixed metal armrests or sled base. Polypropylene single-shell available in 6 different colors: light blue, yellow, beige, dark grey and white. Possibility to have padded and upholstered seat. Stackable up to 6 pieces.

Chaise avec une ligne essentielle et accrocheuse. Piétement en metal chromé ou peint blanc ou noir, disponible avec 4 pieds avec ou sans accoudoirs fixes en metal ou luge. Monococque en polypropylène disponible en 6 couleurs différentes: bleu clair, jaune, beige, gris foncé et blanc. Possibilité d'avoir l'assise rembourrée et revêtue. Empilable jusqu'à 6 pièces.

Silla con una línea esencial y atractiva. Estructura de metal barnizado de color blanco o negro, o bien cromado. Disponible en la versión con base trineo o bien de 4 patas, con o sin apoyabrazos fijos. Carcasa en polipropileno disponible en 6 colores diferentes: azul claro, amarillo, beige, blanco y antracita. Posibilidad de asiento acolchado y tapizado. Apilable hasta 6 piezas.

No Frill 4G

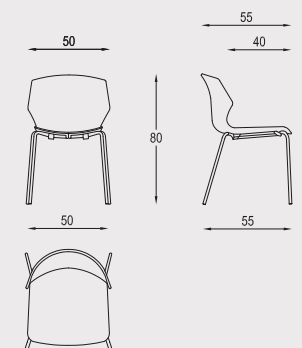

No Frill 4G + braccioli

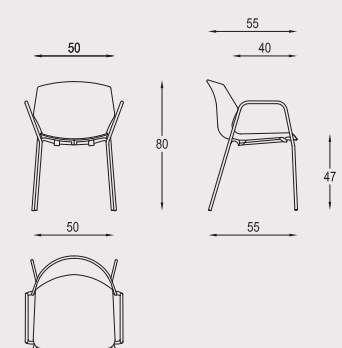

No Frill 4G braccioli + tav

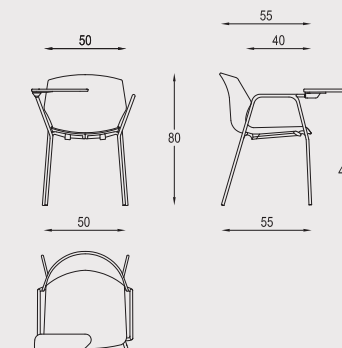

No Frill slitta

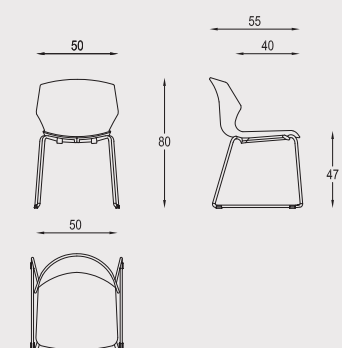

Nuke

Sedia polivalente, totalmente in polipropilene, 100% riciclabile e resistente ai raggi UV, ideale quindi per un utilizzo anche in aree esterne. Struttura unica a 4 gambe con o senza braccioli fissi. Disponibile in 4 varianti di colore: azzurro, giallo, arancione e bianco. Impilabile fino a 6 pezzi.

Multifunctional chair, totally in polypropylene, 100% recyclable and UV-resistant, therefore ideal for use in outdoor areas. 4-leg structure with or without fixed armrests. Available in 4 different colors: light blue, yellow, orange and white. Stackable up to 6 pieces.

Chaise polyvalente, entièrement en polypropylène, 100% recyclable et résistant aux rayons UV, idéale pour l'utiliser dans l'extérieurs aussi. Structure à 4 pieds avec ou sans accoudoirs fixes. Disponible en 4 couleurs différentes: bleu clair, jaune, orange et blanc. Empilable jusqu'à 6 pièces.

Silla versátil, realizada totalmente en polipropileno, 100% reciclable y resistente a los rayos UV, ideal además para exteriores. Estructura de 4 patas con o sin apoyabrazos fijos. Disponible en 4 colores diferentes: azul claro, amarillo, naranja y blanco. Apilable hasta 6 piezas.

Nuke

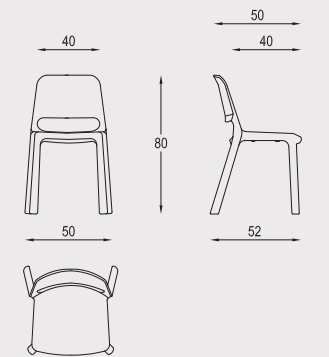

Nuke + braccioli

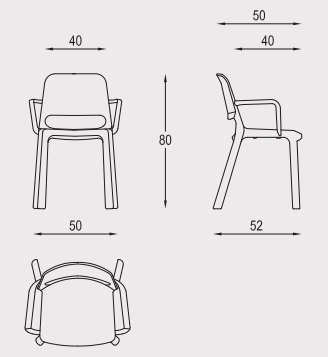

Oblò

Sgabello innovativo multiuso, ideale per la seduta attiva e a breve termine grazie alla base oscillante. Base rotonda con colonna centrale in metallo verniciato nero a polveri epossidiche con alzata gas, trattamento anti-scioglimento del basamento oscillante; seduta sagomata con struttura in legno multistrato imbottita in schiuma di poliuretano e rivestita.

Multipurpose innovative stool, ideal for active and short-term sitting thanks to the swinging base. Round metal base painted in black epoxy powder-coated with gaslift, anti-slip treatment of the oscillating base; Shaped wooden seat, padded in polyurethane foam and upholstered.

Tabouret innovant polyvalent, idéal pour les sessions actives et de courte durée grâce à sa base oscillante. Piétement en métal rond peint en poudre époxy noire avec élévation gaz, traitement anti-glisserment de la base oscillante; assise en bois multicouche moulée, rembourré en mousse de polyuréthane et revêtue.

Taburete innovador multiusos, ideal para asiento activo y de corto plazo gracias a la base oscilante. Estructura redonda de metal barnizado con pintura epoxi, elevador de gas y base oscilante con tratamiento anti-deslizante; asiento moldeado realizado en madera, con acolchado de espuma de poliuretano y acabado tapizado.

Oblò

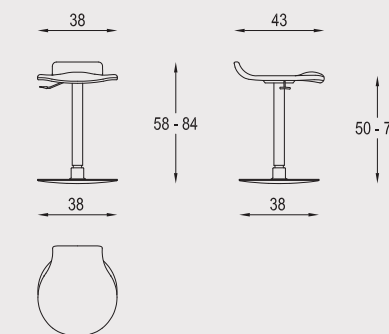

Perfecta

Sedia semplice e funzionale. Scocca in legno multistrato curvato con telaio a 4 gambe in metallo cromato, con o senza braccioli tubolari fissi cromati. Disponibile in 3 essenze legno: rovere naturale, rovere tinto wengé e faggio naturale. Possibilità di bracciolo singolo con tavoletta-scrittoio ripiegabile in polipropilene e sistema di aggancio in file.

Simple and functional chair. Curved multilayer wood structure on 4 chromed metal legs, with or without chromed fixed armrests. Available in 3 wood essences: natural oak, wengé dyed oak and natural beech. Possibility to have the armrest with writing tablet in black nylon and linking system between chairs.

Chaise simple et fonctionnelle. Structure en bois multicouche incurvé sur 4 pieds en métal chromé, avec ou sans accoudoirs fixes chromés. Disponible en 3 coloris: chêne naturel, chêne teinté wengé et hêtre naturel. Possibilité de avoir accoudoirs avec tablette écrioire en nylon noir et système d'achrochage entre sièges.

Silla simple y funcional. Carcasa de madera curvada con 4 patas de metal cromado, con o sin brazos fijos cromados. Disponible en tres acabados de madera: roble natural, roble wengé y haya natural. Posibilidad de brazos con mesa-escritorio plegable y piezas de unión de filas.

Perfecta

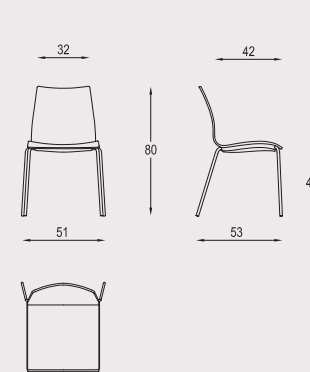

Perfecta + 2 braccioli

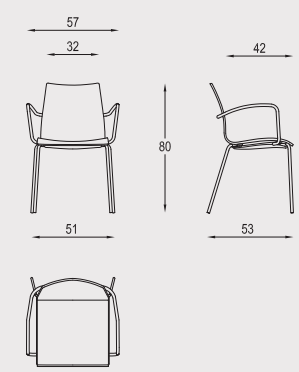

Perfecta + bracciolo + tavolino

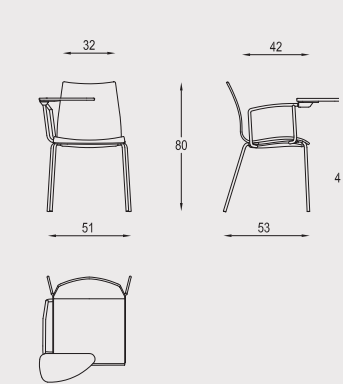

Red Hot

Sedia dalla linea simpatica, grazie allo schienale sagomato. Telaio in metallo verniciato bianco, nero oppure cromato, disponibile nella versione base slitta o a 4 gambe. Monoscocca in polipropilene disponibile in 4 varianti di colore: azzurro, giallo, bianco e antracite. La scocca può essere anche completamente imbottita e rivestita. Impilabile fino a 6 pezzi. Disponibile anche in versione sgabello a 4 gambe cromato o a basamento centrale con alzata gas.

Nice chair with shaped backrest. Painted frame white or black or chromed, available with sled base or on 4 legs. Polypropylene single shaped shell in 4 different color: light blue, yellow, white and dark grey. The shell could be padded and upholstered. Stackable up to 6 pieces. Available also in stool version on 4-chromed legs or with round chromed base with height adjustment.

Chaise avec une ligne sympa grâce à son dossier moulé. Piètement peint blanc ou noir ou chromé, disponible en version luge ou 4 pieds. Monocoque moulée en polypropylène en 4 couleurs différentes: bleu clair, jaune, blanc et gris foncé. La coque peut être complètement rembourrée et revêtue. Empilable jusqu'à 6 pièces. Disponible aussi en version tabouret fixe chromé à 4 pieds ou avec piètement central avec élévation gaz.

Silla de estilo desenfadado con respaldo moldeado. Estructura de metal barnizado blanco, negro o con acabado cromado. Disponible en las versiones con base trineo o de 4 patas. Carcasa en polipropileno disponible en 6 colores diferentes: azul claro, amarillo, blanco y antracita. La carcasa puede acolcharse y tapizarse por completo. Apilable hasta 6 piezas. La versión taburete cromado de 4 patas y la versión con base redonda y ajustador de altura también están disponibles.

Red Hot 4G

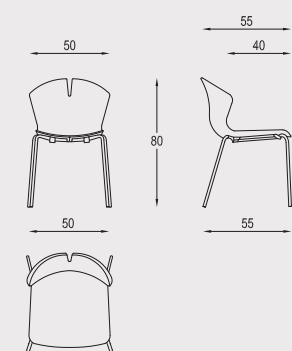

Red Hot slitta

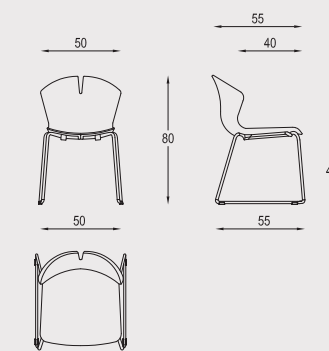

Red Hot stool 4G

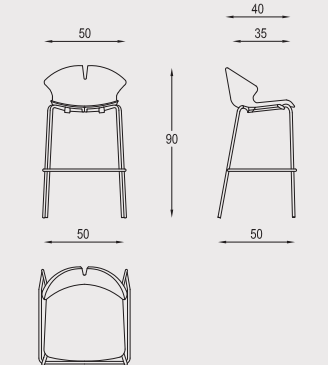

Red Hot stool gas

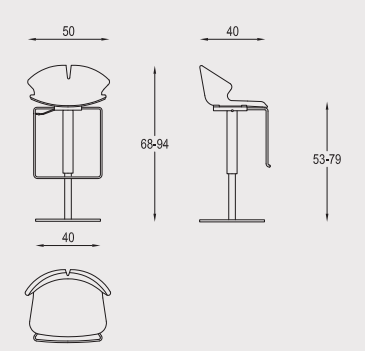

Rocket

Serie di appendiabiti con struttura in metallo verniciato a polveri epossidiche, ideale per la collettività in generale. L'appendiabiti da parete consente, in uno spazio ridottissimo, di appendere almeno tre capi; la versione da terra ha basamento tondo centrale con portaombrelli ed è strutturato con nove ganci.

Range of coat rack with metal frame epoxy powder-coated, ideal for public spaces in general. The wall-mounted coat rack takes up very little space and allows for up to three garments to be hung. The coat stand, featuring nine pegs, has circular base with umbrella holder.

Gamme de porte-manteau en métal peint en poudres époxy, idéal pour la collectivité en général. Le porte-manteau mural prend très peu de place et permet de suspendre au moins trois vêtements. Le porte-manteau a un piétement central avec porte-parapluie et neuf patères.

Gama de percheros con estructura en metal barnizado con pintura epoxi, ideal para todos los públicos.

El perchero de pared ocupa muy poco espacio y permite colgar al menos tres prendas. El otro perchero tiene una base circular con paragüero y nueve enganches.

Rocket

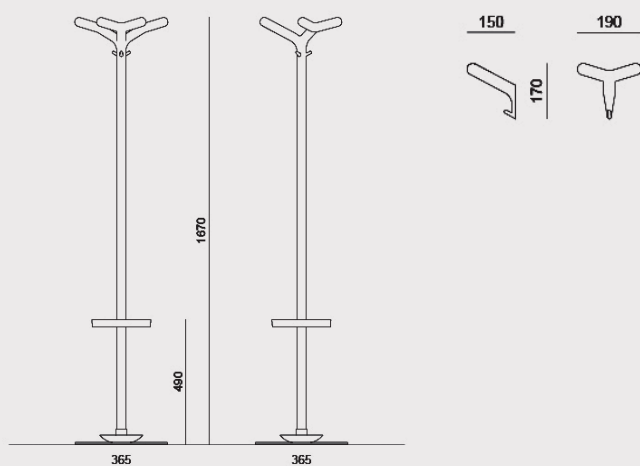

www.diemmeoffice.com | dm@diemmeoffice.com

